

# *Speedball*®

## ETCHING PRESS MANUAL

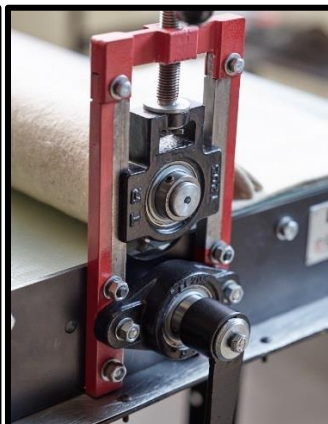

## TABLE OF CONTENTS

<b>Delivery Notes</b>	<b>3</b>
<b>Unpacking</b>	<b>4</b>
<b>Floor Stands</b>	<b>6</b>
<b>Safety Tips</b>	<b>6</b>
<b>Maintenance</b>	<b>7</b>
<b>Diagram</b>	<b>8</b>
<b>Warranty Card</b>	<b>9</b>

This manual is applicable to the following Speedball Etching Press models:

- [004230] 12 x 24 Tabletop Phenolic Bed; Direct Drive; Crank Handle
- [004231] 12 x 24 Tabletop Metal Bed; Direct Drive; Crank Handle
- [004232] 12 x 24 Tabletop Phenolic Bed; Gear Drive; Crank Handle
- [004233] 12 x 24 Tabletop Metal Bed; Gear Drive; Crank Handle
- [004234] 24 x 36 Tabletop Phenolic Bed; Gear Drive; Star Wheel
- [004235] 24 x 36 Tabletop Metal Bed; Gear Drive; Star Wheel

## **DELIVERY NOTES**

Minimum Width of Door Opening Required:

For 12 x 24 models: 24in.

For 24 x 36 models: Phenolic Bed- 34in. | Metal Bed- 36in.

## **FLOOR SPACE RECOMMENDATION**

The ideal location for your etching press is near natural light, if possible, and away from entry/exit doors.

For 12 x 24 models: 60in.W x 72in. L

For 24 x 36 models: 78in. W x 84in. L

*WARNING: Never install the etching press on uneven floor.*

## **TABLE SPACE RECOMMENDATION**

All tabletop models require a sturdy wooden or metal table with larger footprint than that of the respective etching press model. Table size recommendations are as follows:

For 12 x 24 models:

-Table top size (Minimum): 21in.W x 28 in. L

-Height of top surface of table from floor: 36in.

For 24 x 36 models:

-Tabletop size (Minimum): 30in. W x 38 in. L

-Height of top surface of table from Floor: 32in.

*Note: Width & length of tabletop may be larger than recommendations as it is helpful to keep essential items available when working on with the etching press.*

Tabletop models must be mounted with applicable screws/bolts depending upon the tabletop surface selection. (IE Wooden screws on wooden top surface/table or metal screws/bolts on metal top surface/table.) Speedball tabletop models are provided with factory-fitted mounting brackets and screws for attaching to a wooden surface.

*\*If a Speedball Etching Press Floor Stand will be used, ensure it is on a level surface and prepared for the etching press to be mounted to it appropriately before beginning the unpacking process of the etching press.*

## **UNPACKING**

If you received your Etching Press in a corrugate box/top that was damaged during shipment, be sure to make a full description of the breakage and/or damage as soon as possible. Contact the delivery company immediately and make arrangements for an inspection or return the Etching Press to their claims department.

### **12 x 24 ETCHING PRESS**

Your 12 x 24 Etching Press is packed in a heavy-duty, corrugated box. Until ready to remove, keep the box on the floor in its upright position as marked on the box.

1. Cut the plastic straps on both the sides of the box.
2. Cut the self-adhesive tape from top of the box.
3. Identify the long side and top of the box (marked on box).
4. Cut the two vertical sides along the dotted lines of the box with a safety box cutter.
5. Flap down the cut side on the floor (the crank lever will be in front).
6. Carefully remove the polystyrene blocks, pulling them out from the top of the box. Set aside.
7. Locate and set aside the tool bag, which contains the following:
  - (2) Wrenches (10-13 mm)
  - (1) Black polymer handle with hardware (M8 hex bolt, washer, M8 hex nut)
  - (4) Phillips head mounting screws (wooden surface)
8. Gently slide the press from the box onto the floor.
9. With both hands, carefully lift the press from the ends gripping the tie rods and place it on your desired tabletop. *Note: Keep the crank lever off the tabletop surface.*
10. Using the provided Philips head mounting screws, secure the press onto your desired tabletop surface.
11. Using the provided hardware (M8 hex bolt, washer and M8 hex nut) attach the black polymer handle to the end of the crank lever.
12. Clean the press thoroughly by removing packing material, dust, oil and debris.
13. **For Metal Press Bed Models:** Remove the yellow safety locks fitted at opposite corners of the bed. Keep this in a safe place for future use. When the press is not in use, we recommend the yellow safety locks are put in place to prevent any type of injury.

## **24x36 ETCHING PRESS**

Your 24x36 Etching Press is packed and strapped to a 39x39 wooden pallet with a heavy-duty corrugate TOP.

1. Remove the shrink wrap and carefully cut the plastic straps attached to the wooden pallet.
2. Lift off the corrugated box top to remove it from the pallet.
3. Remove the polystyrene blocks and set aside.
4. Using a Philips screwdriver, unscrew the (4) legs of the etching press from mounting clamps that are attached to wooden runners. This will “free” the press from the pallet.
5. Four persons are recommended to lift the press from the pallet to the desired tabletop surface or floor stand\*.
  - *\*See Floor Stand Section **PRIOR** to lifting the press to the stand as you will need to change the legs of the press to correctly place the press on the floor stand.*
  - *The tabletop surface must be strong enough to withstand the weight and pressure of the press.*
6. Locate and set aside the (4) star wheel rods.
7. Locate and set aside the tool bag, which contains the following:
  - (2) Wrenches (10-13 mm and 17-19 mm)
  - (4) Star Wheel Rods and Knobs
8. Attach the Star Wheel Rods & Knobs by screwing the end in to each of the 4 slots located next to the gear box.
9. Clean the press thoroughly by removing packing material, dust, oil and debris.

For your safety, the metal press bed is locked in place. DO NOT rotate the star wheel until the following steps are completed:

10. Remove the yellow safety locks fitted at opposite corners of the bed. Keep this in a safe place for future use. When the press is not in use, we recommend the yellow safety locks are put in place to prevent any type of injury.
11. Rotate the star-wheel slowly a quarter of a turn in both directions 3-4 times. If press bed is travelling smoothly, turn the star-wheel by one full turn.

## **FLOOR STANDS**

If you purchased a Speedball Etching Press Floor Stand, you need to ensure the stand is completely level. If uneven, adjust the M10 hex bolts provided at the bottom of each leg. Tighten the hex nut after setting up the bolt.

### **Floor Stand Attachment**

- Removing the press bed from the etching press.
- Using one of the wooden runners from the pallet, carefully slide the block of wood under one side of the press to lift up the press so you can get to the legs of the press.
- Remove the legs currently attached to the etching press.
- Replace the legs with the provided Floor Stand mounting clamps/legs.
- Once complete, repeat on the other side.

## **SAFETY TIPS**

1. Install the etching press on level, durable, and strong surface.
2. DO NOT remove metal guard (safety cover) on gear-drive etching presses.
3. DO NOT lubricate spur gears or ball bearings; these components are lifetime lubricated.
4. DO NOT place any hard objects, specifically metal objects, between rollers and press bed.
5. DO NOT put uneven substrates (e.g. tote bag) through the etching press. The etching press is designed for printing traditional printmaking substrates.
6. Keep hands, long hair, jewelry and loose clothing away from rollers and crank handles when operating the etching press.
7. Keep out of the reach of small children.
8. DO NOT attempt to lift or move the 24x36 etching press by yourself. The etching press should be lifted with at least three other individuals to avoid injury.
9. DO NOT modify the etching press in any way as this will void the warranty.

## **MAINTENANCE**

1. For proper operation, always keep the etching press clean and away from water.
2. Prior to each printing session, check and if necessary, remove any dust, excess oil, particles, ink, etc. from the press.
3. Perform the following steps periodically:
  - Apply an all-purpose lubricating oil on screw threads and top roller sliding guides.
  - Check all the bolts and nuts, if required, tighten them.
  - Clean pressure adjusting screws accordingly. (applicable to 24x36 press only)
4. The pressure screws and the upright columns should be kept coated with a light grease; this will help to prevent corrosion and ensure smooth operation.
5. When the press is not in use for an extended period of time (i.e. for more than 15 days):
  - Adjust the upper roller to the highest level.
  - The phenolic bed can be removed and stored.
  - Attach the yellow safety locks to the press. (Metal Bed versions only)
  - Cover the press to protect it from dust and debris.

## DIAGRAM(S)

### 12 x 24 ETCHING PRESS | DIRECT DRIVE

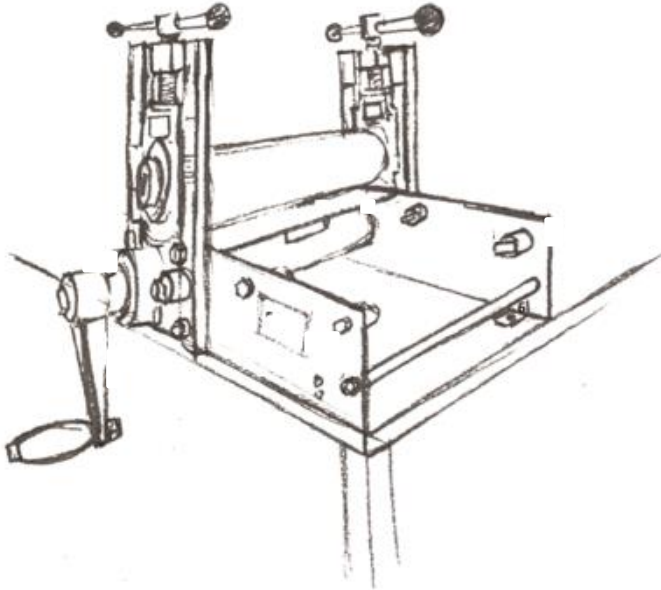

1. Black Plastic Handle
2. Crank Lever
3. Gear Drive System
4. Pressure Lever
5. Pressure Screw
6. Top Nut
7. Top Roller
8. Bed Plate
9. Bottom Roller
10. Eccentric Guide
11. Tie Rod
12. Mounting Clamps
13. Name Plate

### 12 x 24 ETCHING PRESS | GEAR DRIVE

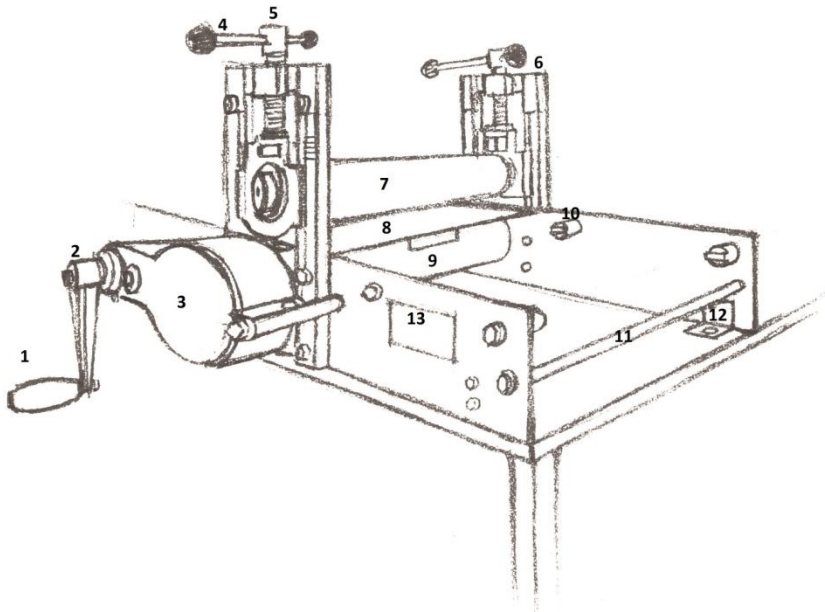

1. Black Plastic Handle
2. Crank Lever
3. Gear Drive System
4. Pressure Lever
5. Pressure Screw
6. Top Nut
7. Top Roller
8. Bed Plate
9. Bottom Roller
10. Eccentric Guide
11. Tie Rod
12. Mounting Clamps
13. Name Plate



## **WARRANTY**

Speedball Art Products, LLC warrants this Speedball Etching Press to be free from defects in materials and workmanship under normal use and service, that would affect its operation for a period of 5 (five) years from the date of purchase. This warranty applies to the original buyer only and cannot be extended to a successive buyer even within the warranty period.

### **Warranty Coverage**

The obligation of this warranty shall be limited to replacing any part of the Etching Press which, at the discretion of the Company, shall be proven defective in materials or workmanship under normal use and service during the time period commencing with the date of purchase. All expenses related to replacing or repairing a defective part under this warranty shall be assumed by Speedball Art Products. The limit of this warranty includes the product only and not any loss of work time or contract due to inability to use the Etching Press. Full Etching Press replacement will be at the discretion of the Company and will only be considered for claims initiated within 30 (thirty) days of purchase.

### **Warranty Exclusions**

This warranty does not apply to any costs, repairs, or services for the following:

1. Service calls to correct the installation of the Etching Press, or to explain the usage of the product to the buyer.
2. Repairs necessitated by use other than normal use.
3. Damage resulting from misuse, abuse, accidents, or improper installation.
4. Corrective work necessitated by repairs made by anyone other than Speedball.
5. Damage exceeding the purchase cost of the product.
6. Damage by extreme circumstances, such as flood, lightning, or natural disaster, war declared or undeclared.

### **Warranty Registration**

The buyer must register their Etching Press within 30 (thirty) days from date of purchase for the warranty to be valid. There are two ways to complete the Etching Press Warranty Card:

1. Printed Warranty Card included within Etching Press Manual
2. Online – [www.SpeedballArt.com](http://www.SpeedballArt.com) under Etching Press Warranty Registration  
<https://www.speedballart.com/customer-service/speedball-etching-press-warranty/>

### **Warranty Replacement**

If parts are in need of repair or replacement, the buyer can contact Speedball three ways:

1. Online – <https://www.speedballart.com/customer-service/>
2. Phone – 1.800.898.7224
3. Email – [placeanorder@speedballart.com](mailto:placeanorder@speedballart.com)

---

---

---

PLACE  
STAMP  
HERE

## Speedball®

**2301 Speedball Rd.  
Statesville, NC 28677**

**ETCHING PRESS WARRANTY CARD – PLEASE PRINT CLEARLY**

Name/Company: \_\_\_\_\_

Address: \_\_\_\_\_

City: \_\_\_\_\_ State: \_\_\_\_\_ ZIP: \_\_\_\_\_

Daytime Phone: (\_\_\_\_) \_\_\_\_\_ - \_\_\_\_\_

Email Address: \_\_\_\_\_

Purchase Date: \_\_\_\_\_

Model Number: \_\_\_\_\_

Purchased From: \_\_\_\_\_

Address: \_\_\_\_\_

City: \_\_\_\_\_ State: \_\_\_\_\_ ZIP: \_\_\_\_\_

Please fill out the attached warranty card and return to Speedball within 30 days of purchase.